



Per la sua omonimia con un frammento della periferia milanese, il nome Rho si specchia in questo panorama disgregato -il panorama del nostro essere oggi abitanti metropolitani- e si carica ancor più di senso. Rho è la somma di più significati e la formula immaginaria di misteriosi passaggi e cifrari liturgici. La collezione è fatta di tavoli, scrivanie, contenitori, cassettiere, librerie, ma in realtà è costituita da singoli pezzi quasi da comporre liberamente: due gambe ad L di differenti misure, un piano sagomato a biscotto o a osso di seppia, dei distanziali/appoggi in metallo, dei pannelli differientemente risolti, dei piedi derivati dalla forma dei distanziali, delle cassettiere monolitiche e monumentali e delle continue deformazioni di tutto ciò. Il materiale principe è il legno, in due essenze ad infinite possibilità combinatorie. Ogni essenza è in qualche modo matrice delle altre: dal wengé allo zebrano e viceversa. Una combinazione che assomiglia alla nostra stessa condizione di uomini contemporanei.

Named after one of the Milan banlieues, the name Rho mirrors this disjointed panorama - the landscape of our being city dwellers - and thus takes on further connotations. Rho is the summa of various meanings and the imaginary formula for mysterious passages and liturgical codes. The collection includes tables, desks, containers, drawer units, bookcases but in fact includes a series of individual pieces which can practically be assembled according to personal requirements: two L-shaped legs in different sizes, a biscuit or cuttlebone shaped flat surface, metal spacers/supports, different solutions for panels, feet derived from the shape of the spacers, monolithic monumental drawer units and constant distortions of all of the above. The principal material is wood, two species with an infinite range of rich combinations. Each type is to a certain extent a matrix of the others, from wengé to zebrano and vice versa. A combination which bears a resemblance to our own conditions as citizens of the modern world.

Du fait de son homonymie avec un fragment de la banlieue milanaise- la ville de Rho – la ligne des produits Rho prend ainsi pour modèle ce panorama éparpillé – le panorama qui aujourd’hui fait de nous des habitants métropolitains – et s’enrichit de son sens. Rho est une somme de significations et une formule imaginaire de passages mystérieux et codes chiffrés liturgiques. La collection se compose de tables, bureaux, conteneurs, caissons, bibliothèques mais en réalité elle est constituée de morceaux séparés que l’on peut combiner librement : deux portants en forme de L de différentes tailles, un dessus au profil d’un biscuit ou d’un os de seiche, des entretoises/appuis en métal. Des panneaux réalisés de différentes façons, des pieds dérivés de la forme des entretoises, des caissons monolithiques et monumentaux et de continuelles déformations de tout cela. Le principal matériel utilisé est le bois, disponible en deux essences avec des possibilités de combinaisons infinies. Chaque essence est de quelque façon matrice des autres : du wengé au zebrano et vice-versa. Un assemblage qui ressemble à notre condition d’hommes d’aujourd’hui.





L'immagine è piantata per terra, decisa e forte ed al contempo leggera ed aerea.

The image is grounded, decisive and strong while at the same time light and airy.

L'image est solide, forte et robuste et en même temps légère et aérienne.



La composizione astratta per linee, segni e superfici, avvicina la collezione alle esperienze italiane dell'astrattismo.

The composition is abstract in lines, signs and surfaces, approaching this collection to the Italian experience of the Abstract movement.
La composition abstraite par lignes, signes et surfaces rapproche la collection des expériences des peintres italiens de l'Abstrait.



REDA

Rho. Si sovrappongono ricordi e volumi delle geometrie e dissimmetrie della periferia milanese.

Rho. Overlapping memories and shapes of the geometry and dissymmetry of the Milan periphery.
Rho. Souvenirs et volumes des géométries et dissymétries de la banlieue milanaise se superposent.



La composizione di questo sistema direzionale allude alle logiche di formule algebriche, che rimandano a combinazioni infinite.

The composition of this directional system hints at the logic of algebraic formula which allows infinite combinations.
La composition de ce système de direction fait allusion aux logiques de formules algébriques, qui renvoient à des assemblages infinis.













Le tre varianti cromatiche delle paratie in cristallo rosso rubino, verde inglese e nero si armonizzano con le ante dei contenitori.

The three possibilities of colours for modesty panels in ruby-red, english green and black glass match perfectly the doors of the complementary elements.
Les trois possibilités de couleur pour les voiles en verre rouge rubis, vert anglais et noir s'harmonisent parfaitement aux portes des éléments de complément.

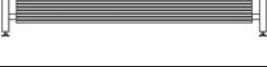
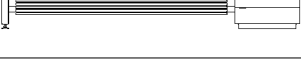

Il nome Rho, formula inesistente, richiama una magica analogia con la chimica e la manifesta come struttura logica del progetto.

The name Rho, a non-existent formula, creates a magical analogy with chemistry and shows it to be the logical structure of the project.
Le nom Rho, formule inexistante, rappelle une analogie magique avec la chimie et la désigne comme étant la structure logique du projet.

ARTICOLO ITEM ARTICLE	CODICE E DESCRIZIONE CODE AND DESCRIPTION CODES ET DESCRIPTIONS	DIMENSIONI DIMENSIONS DIMENSIONS
	R215F R245P Scrivania con paratia Desk with bulkhead Bureau avec cloison	cm 215x100xh73 cm 245x100xh73
	R245C R275P Scrivania con paratia e cassetiera portante Desk with bulkhead and supporting drawer unit Bureau avec cloison et caisson d'appui	cm 245x100xh73 cm 275x100xh73
	R215K R245K Scrivania con paratia in cristallo Desk with glass bulkhead Bureau avec cloison en verre	cm 215x100xh73 cm 245x100xh73
	R245KC R275K Scrivania con paratia in cristallo e cassetiera portante Desk with glass bulkhead and supporting drawer unit Bureau avec cloison en verre et caisson d'appui	cm 245x100xh73 cm 275x100xh73
	R245ME Scrivania con paratia a mensola Desk with shelf bulkhead Bureau avec cloison à console	cm 245x100xh73
	R275ME Scrivania con paratia a mensola e cassetiera portante Desk with shelf bulkhead and supporting drawer unit Bureau avec cloison à console et caisson d'appui	cm 275x100xh73
	R215FL R245LI Scrivania con paratia a listelli Desk with slat bulkhead Bureau avec cloison à listels	cm 215x100xh73 cm 245x100xh73
	R245CL R275LI Scrivania con paratia a listelli e cassetiera portante Desk with slat bulkhead and supporting drawer unit Bureau avec cloison à listels et caisson d'appui	cm 215x100xh73 cm 275x100xh73
	RD Allungo senza cassetiera Extension without drawer unit Rallonge sans caisson	cm 120x46xh68
	RDC Allungo con cassetiera Extension with drawer unit Rallonge avec caisson	cm 120x46xh68
	RTA Tavoli appoggio per scrivanie Briefing table Table convivialité	cm 130x100xh70

SCRIVANIE E COMPLEMENTI PER SCRIVANIE

Le scrivanie della collezione Rho sono caratterizzate dalla intercambiabilità delle parti sotto il profilo della forma e del colore. I piani in legno dalla elegante sagoma affusolata possono essere richiesti con l'inserito in cristallo temperato in tre varianti cromatiche: verde, bordeaux, nero.

I fianchi (grande e ridotto) dalla particolare forma sostengono i piani e si appoggiano al suolo grazie a distanziali in alluminio che danno slancio alla "costruzione".

La possibilità di sostituire un fianco con la cassetiera portante arricchisce l'estetica e la funzionalità.

Per completare l'insieme si può optare per quattro modelli di pannello frontale:

a listelli di legno,

a pannello,

a pannello in cristallo,

a mensola.

Quattro le varianti cromatiche: completamente in zebrano, completamente in wengè, con piano e pannelli frontali in zebrano e fianchi e/o cassetiera portante in wengè, con piano e pannelli frontali in wengè e fianchi e/o cassetiera portante in zebrano.

Le scrivanie possono essere equipaggiate con una serie di complementi, come gli allunghi con e senza cassetiera portante: essi ampliano il piano di lavoro liberandolo da strumenti quali il telefono, il computer ecc.

Gli allunghi senza cassetiera possono essere equipaggiati con cassetto portatastiera. Il cassetto portacancelleria può essere inserito nella posizione più adatta all'utilizzo. Nel vano ad anta delle cassettiere portanti trova alloggio la cassaforte per custodire documenti riservati.

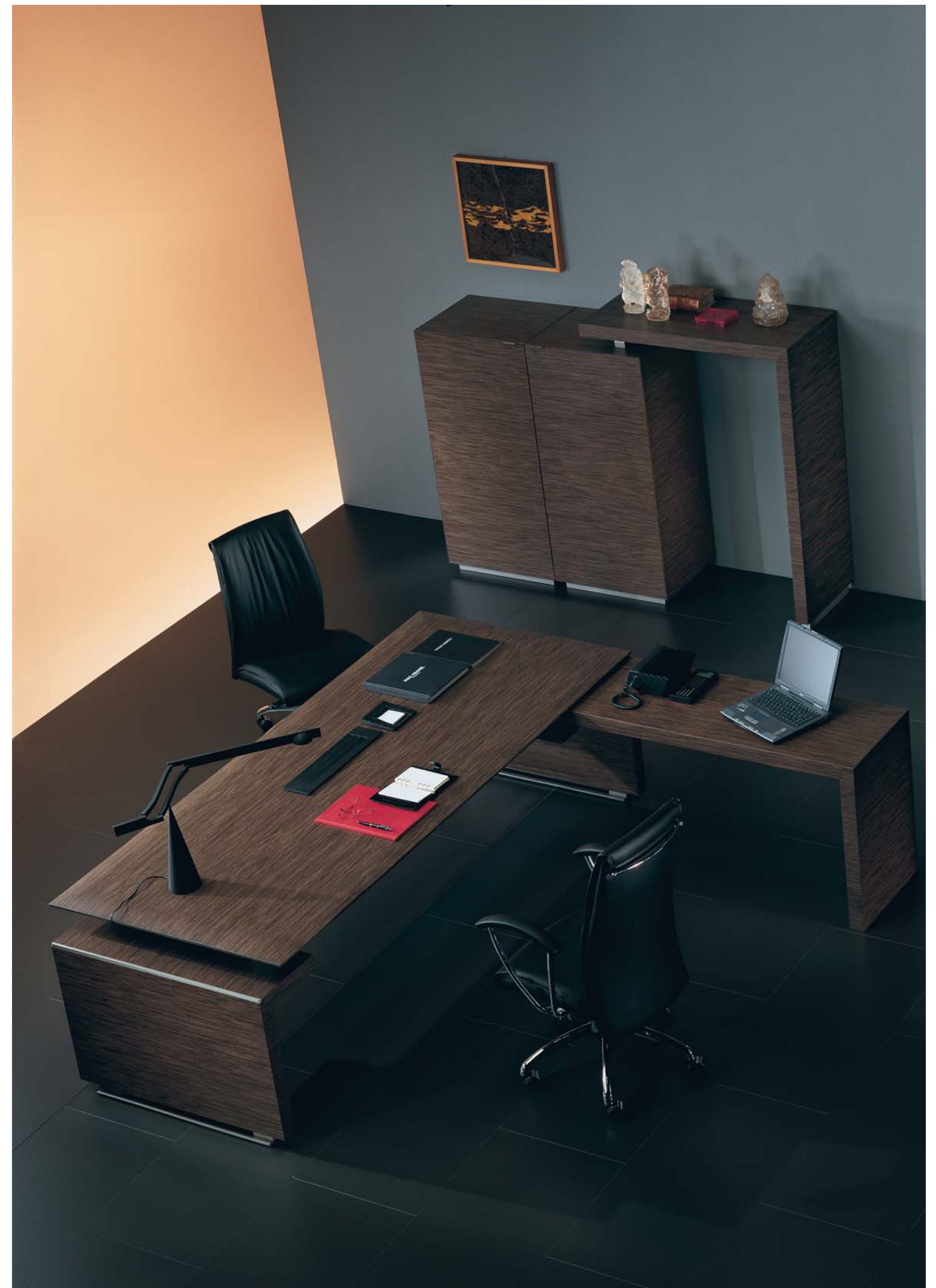



ZB
Zebrano
Zebrano
Zebrano



WG
Wengé
Wengé
Wengé

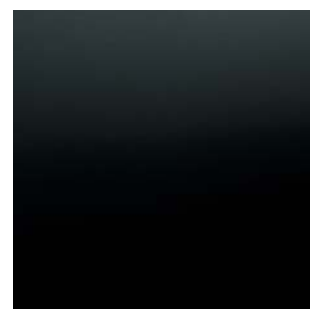

N
Nero
Black
Noir

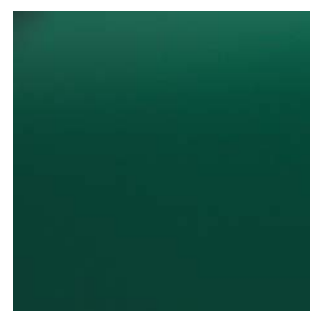

V
Verde
Green
Vert

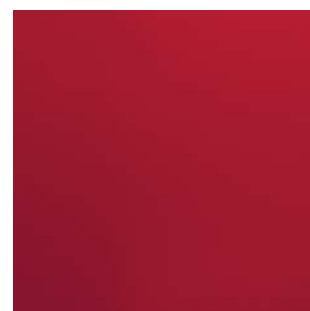

B
Rosso
Ruby-red
Bordeaux

DESKS AND DESK ACCESSORIES

The desks in the Rho collection are notable for the modularity of its components as far as shape and color are concerned. The wooden surfaces with their elegant tapering shape may be ordered with a tempered glass insert in three different colours: green, wine red, and black. The sides (large and reduced) with their original shape support the work surfaces and stand on aluminium spacers which gives an overall streamlined appearance. The option of replacing one side with a supporting drawer unit adds further aesthetic and functional possibilities. Four models of front panels are available:

- Wooden slats,
- With panel,
- With a crystal panel,
- With shelf.

Four colour combinations: all zebrano; all wengé; zebrano surface and front panels and wengé sides and/or drawer unit; wengé work surface and front panels and zebrano sides and/or drawer unit. Desks can be fitted with a series of accessories such as extensions with or without supporting drawer units: these serve to extend the work surface, freeing it from equipment such as the phone, computer, etc.

The extensions without supporting drawer unit can be fitted with a keyboard drawer. The stationary drawer can be fitted wherever required. The safe for confidential documents is behind the door of the supporting unit.

BUREAUX ET ACCESSOIRES POUR BUREAUX

Les bureaux de la collection Rho se distinguent par le caractère interchangeable des parties en termes de forme et de couleur. Les dessus en bois au profil élégant et fuselé peuvent être commandés avec l'insertion en cristal tempéré disponible en trois variantes chromatiques: vert, bordeaux, noir. Les côtés (grand et réduit) ont une forme particulière, ils soutiennent les dessus et s'appuient au sol grâce à des entretoises en aluminium qui donnent de l'élan à la "construction". La possibilité de remplacer un côté avec le caisson d'appui enrichit l'esthétique et la fonctionnalité. Pour compléter l'ensemble on peut opter pour quatre modèles de panneaux frontaux:



- à listels de bois,
- à panneau,
- à panneau en verre,
- à console.

Les variantes chromatiques sont au nombre de quatre: complètement en zebrano, complètement en wengé, avec dessus et panneaux frontaux en zebrano et côtés et/ou caisson d'appui en zebrano, avec dessus et panneaux frontaux en wengé et côtés et/ou caisson d'appui en zebrano. Les bureaux peuvent être équipés d'une série d'accessoires, comme les rallonges avec et sans caisson d'appui: ces dernières étendent le plan de travail en libérant d'instruments tels que le téléphone, l'ordinateur etc. Les rallonges sans caisson peuvent être équipées de tiroir porte-clavier. Le tiroir à fournitures de bureau peut être introduit dans la position la plus adaptée à son utilisation. A l'intérieur du caisson d'appui se trouve le coffre-fort pour y conserver des documents privés.



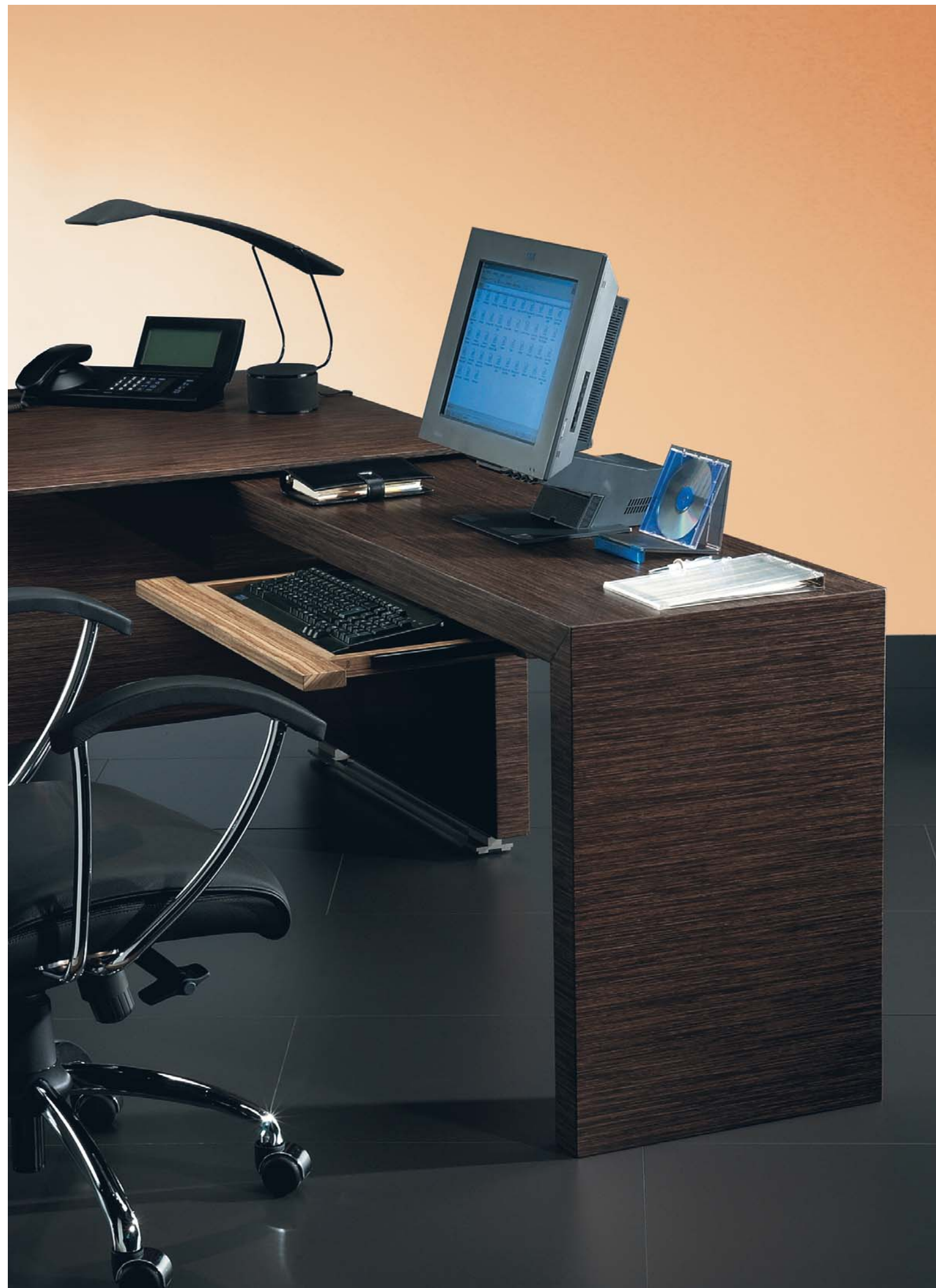

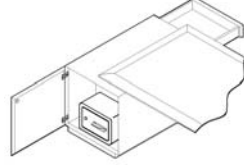
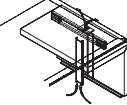

ARTICOLO ITEM ARTICLE	CODICE E DESCRIZIONE CODE AND DESCRIPTION CODES ET DESCRIPTIONS	DIMENSIONI DIMENSIONS DIMENSIONS
	RCPC Cassetto porta cancelleria Stationary drawer Tiroir à fournitures de bureau	cm 48x44
	RCPT Cassetto porta tastiera Keyboard drawer Tiroir porte-clavier	cm 64x35
	RCSS Cassaforte elettronica a scheda Card-operated electronic safe Coffre-fort électronique à carte	
	REL Elettrificazione scrivania Desk wire management Passage cable pour bureau	



ARTICOLO ITEM ARTICLE	CODICE E DESCRIZIONE CODE AND DESCRIPTION CODES ET DESCRIPTIONS	DIMENSIONI DIMENSIONS DIMENSIONS
	RLB193.1C Libreria da cm. 193 con una cassettera 93 cm bookcase with drawer unit Bibliothèque de cm. 193 avec un caisson	cm 193x46xh75
	RLB193.1M Libreria da cm. 193 con una anta in legno 193 cm bookcase with wood door Bibliothèque de cm. 193 avec un volet en bois	cm 193x46xh75
	RLB193.1MV Libreria da cm. 193 con una anta in cristallo 193 cm bookcase with glass door Bibliothèque de cm. 193 avec un volet en cristal	cm 193x46xh75
	RLB253.1C Libreria da cm. 253 con una cassettera 253 cm bookcase with drawer unit Bibliothèque de cm. 253 avec un caisson	cm 253x46xh75
	RLB253.1M Libreria da cm. 253 con una anta in legno 253 cm bookcase with wood door Bibliothèque de cm. 253 avec un volet en bois	cm 253x46xh75
	RLB253.1MV Libreria da cm. 253 con una anta in cristallo 253 cm bookcase with glass door Bibliothèque de cm. 253 avec un volet en cristal	cm 253x46xh75



RC
Elemento cassettera
Drawer unit element
Élément à caisson

RM
Elemento ad anta in legno
Wood door element
Élément avec volet en bois

RMF
Elemento ad anta in legno con frigo
Wood door with fridge element
Élément avec volet en bois et frigidaire

RMV
Elemento ad anta in cristallo
Glass door element
Élément avec un volet en cristal

Può essere completata con 1, 2 o 3 elementi complementari
May be finished with 1, 2 or 3 complementary elements
Complètement possible à 1, 2 ou 3 éléments complémentaires

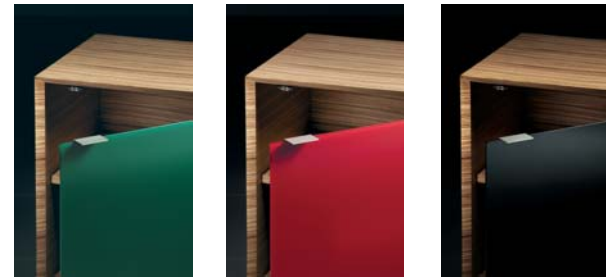

CONTENITORI: LIBRERIE BASSE MEDIE ALTE

Il programma di contenitori della collezione Rho, proposto nelle tre altezze cm 75, cm 138, cm 200, completa in maniera organica la funzione delle scrivanie, riproponendone la filosofia associativa degli elementi e dei cromatismi.

Il prezioso disegno e la minuziosa ricerca del dettaglio sono risultato di maestria ebanistica e propongono forme pure e funzionali.



CONTAINERS: LOW MEDIUM HIGH BOOKCASES

The Rho collection proposes containers in three different heights: 75cm, 138cm and 200 cm, as a natural extension of the function of the desk, with the same associations of elements and colour schemes. The fine design and meticulous attention to detail are the fruit of cabinet-making craftsmanship and create pure, functional shapes.

CONTENEURS: BIBLIOTHEQUES BASSES MOYENNES HAUTES

Le programme de conteneurs de la collection Rho, proposé en trois hauteurs: cm 75, cm 138, cm 200, complète de façon organique la fonction des bureaux, en reproposant la philosophie associative de leurs éléments et chromatismes. Le dessin précieux et la recherche minutieuse du détail sont le résultat de la culture de l'ébéniste qui propose des formes pures et fonctionnelles.

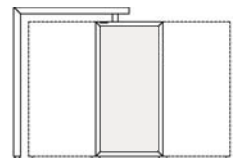
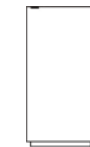

ARTICOLO ITEM ARTICLE	CODICE E DESCRIZIONE CODE AND DESCRIPTION CODES ET DESCRIPTIONS	DIMENSIONI DIMENSIONS DIMENSIONS
	RAR138.1A Libreria h 138 con una anta in legno 138 h bookcase with wood door Bibliothèque h 138 avec un volet en bois	cm 133x46xh138
	RAR138.1AV Libreria h 138 con una anta in cristallo 138 h bookcase with glass door Bibliothèque h 138 avec un volet en cristal	cm 133X46XH138
	REC Elemento ad anta in legno Wood door element Élément avec volet en bois	cm 60X46XH124
	RECV Elemento ad anta in cristallo Black glass door element Élément avec un volet en cristal	cm 60X46XH124

Può essere completata con 1, 2 o 3 elementi complementari
May be finished with 1, 2 or 3 complementary elements
Complètement possible à 1, 2 ou 3 éléments complémentaires



ARTICOLO
ITEM
ARTICLE

CODICE E DESCRIZIONE
CODE AND DESCRIPTION
CODES ET DESCRIPTIONS

DIMENSIONI
DIMENSIONS
DIMENSIONS

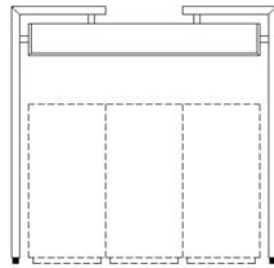

RLH200.1ME

cm 206x46xh200

Libreria h 200 con una mensola
200 h bookcase with one shelf
Bibliothèque h 200 avec un console

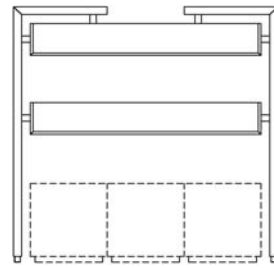

RLH200.2ME

cm 206x46xh200

Libreria h 200 con due mensole
200 h bookcase with two shelves
Bibliothèque h 200 avec deux consoles

Deve essere completata con 1, 2 o 3 elementi complementari
Must be finished with 1, 2 or 3 complementary elements
Complètement à 1, 2 ou 3 éléments complémentaires

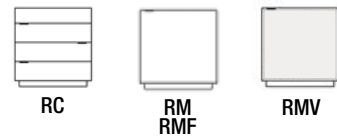

RC

Elemento cassettiera
Drawer unit element
Élément à caisson

cm 60x46xh62

RM

Elemento ad anta in legno
Wood door element
Élément avec volet en bois

RMF

Elemento ad anta in legno con frigo
Wood door with fridge element
Élément avec volet en bois et frigider

RMV

Elemento ad anta in cristallo
Black glass door element
Élément avec un volet en cristal



REC

Elemento ad anta in legno
Wood door element
Élément avec volet en bois

cm 60x46xH124



RECV

Elemento ad anta in cristallo
Black glass door element
Élément avec un volet en cristal

cm 60x46xH124

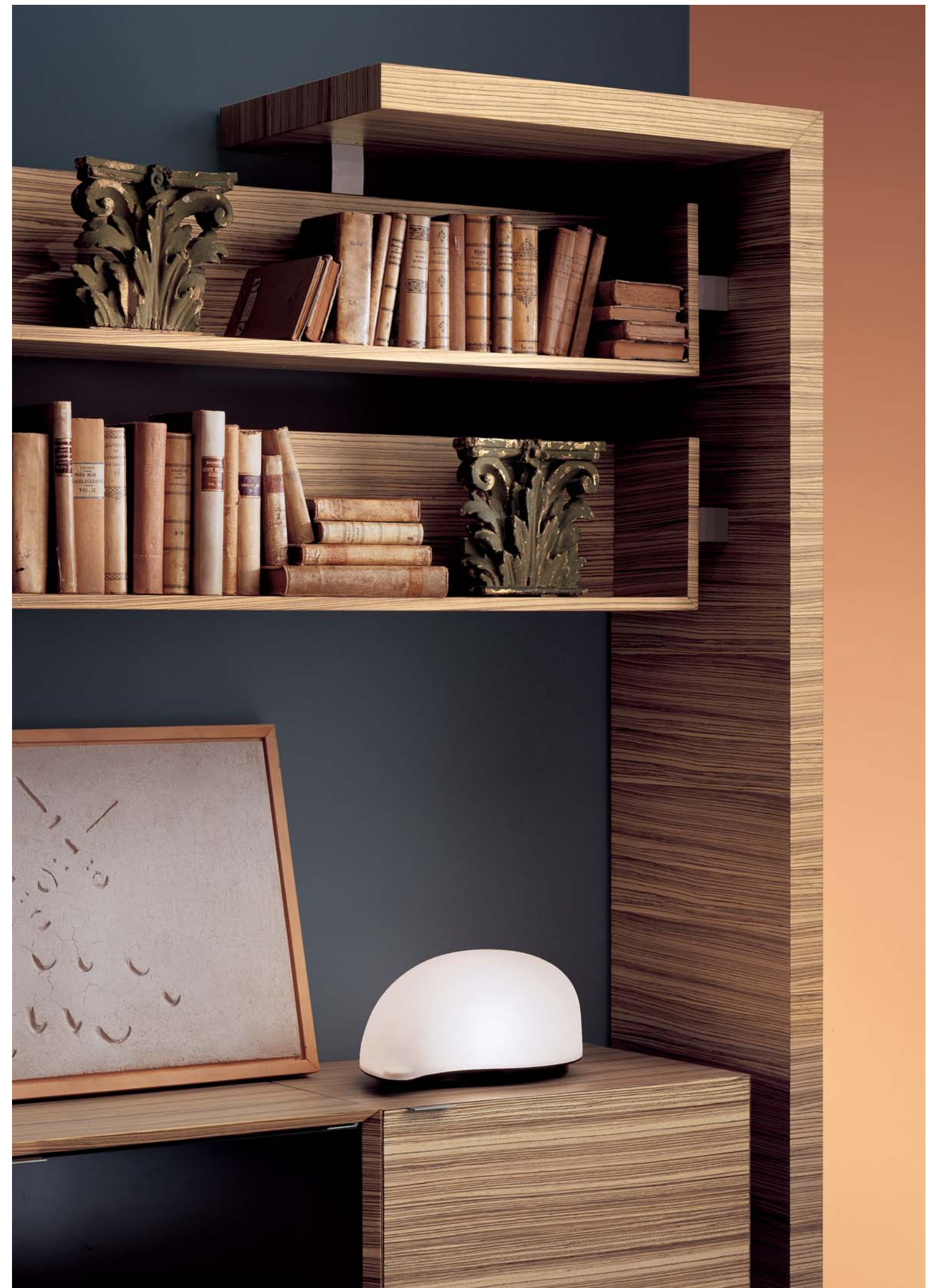
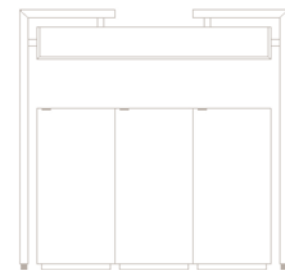
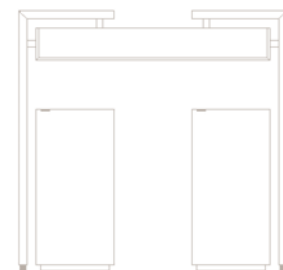
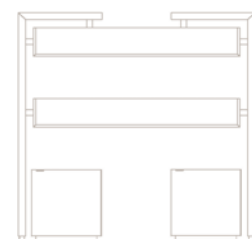

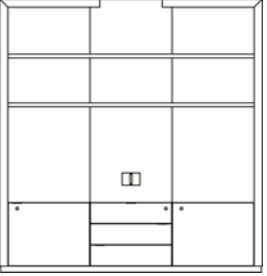
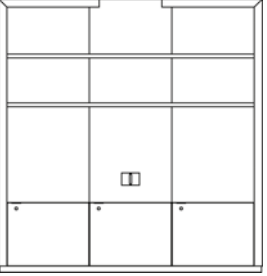

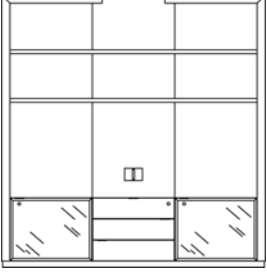
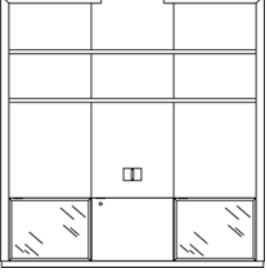
ARTICOLO ITEM ARTICLE	CODICE E DESCRIZIONE CODE AND DESCRIPTION CODES ET DESCRIPTIONS	DIMENSIONI DIMENSIONS DIMENSIONS	ARTICOLO ITEM ARTICLE	CODICE E DESCRIZIONE CODE AND DESCRIPTION CODES ET DESCRIPTIONS	DIMENSIONI DIMENSIONS DIMENSIONS
	RLB192/1 Libreria h 200, 2 mensole, 3 cassetti e 2 ante legno Cupboard h cm.200, 2 shelves, 3 drawer, 2 blind doors Bibliothèque h 200, 2 étagères, 3 tiroirs, 2 portes battantes	cm 192x46xh200		RLB192/3 Libreria h 200, 2 mensole, 3 ante legno Cupboard h cm.200, 2 shelves, 3 blind doors Bibliothèque h 200, 2 étagères, 3 portes battantes	cm 192x46xh200

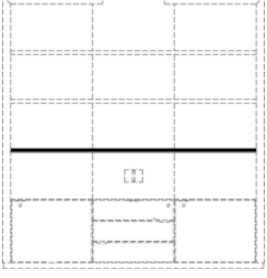
	RLB192/2V Libreria h 200, 2 mensole, 3 cassetti e 2 ante vetro Cupboard h cm.200, 2 shelves, 3 drawer, 2 glass doors Bibliothèque h 200, 2 étagères, 3 tiroirs, 2 portes en verre	cm 192x46xh200		RLB192/4V Libreria h 200, 2 mensole, 1 anta legno, 2 ante vetro Cupboard h cm.200, 2 shelves, 1 blind door, 2 glass doors Bibliothèque h 200, 2 étagères, 1 porte battantes et 2 portes en verre	cm 192x46xh200
--	--	-----------------------	--	---	-----------------------

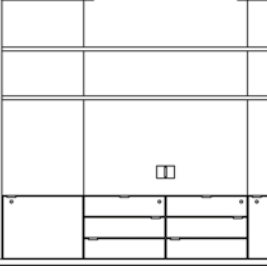
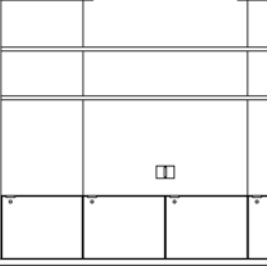
	RME/L192 Mensola per libreria L. 192 Cupboard shelf L. 192 Étagère pour bibliothèque L. 192	cm 192x46			
---	---	------------------	--	--	--

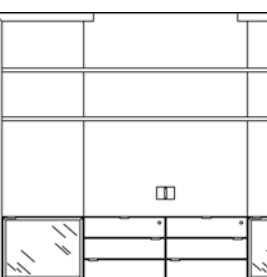
	RLB252/5 Libreria h 200, 2 mensole, 6 cassetti e 2 ante legno Cupboard h cm.200, 2 shelves, 6 drawer, 2 blind doors Bibliothèque h 200, 2 étagères, 6 tiroirs, 2 portes battantes	cm 252x46xh200		RLB252/7 Libreria h 200, 2 mensole, 4 ante legno Cupboard h cm.200, 2 shelves, 4 blind doors Bibliothèque h 200, 2 étagères, 4 portes battantes	cm 252x46xh200
--	--	-----------------------	--	---	-----------------------

	RLB252/6V Libreria h 200, 2 mensole, 6 cassetti e 2 ante vetro Cupboard h cm.200, 2 shelves, 6 drawer, 2 glass doors Bibliothèque h 200, 2 étagères, 6 tiroirs, 2 portes en verre	cm 252x46xh200		RLB252/8V Libreria h 200, 2 mensole, 2 ante legno, 2 ante vetro Cupboard h cm.200, 2 shelves, 2 blind doors, 2 glass doors Bibliothèque h 200, 2 étagères, 2 portes battantes et 2 portes en verre	cm 252x46xh200
--	--	-----------------------	--	---	-----------------------

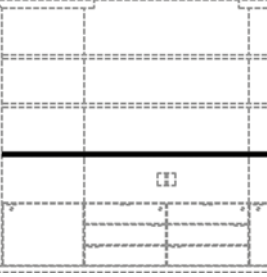
	RME/L252 Mensola per libreria L. 252 Cupboard shelf L. 252 Étagère pour bibliothèque L. 252	cm 252x46			
--	---	------------------	--	--	--

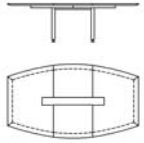
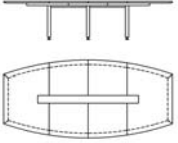
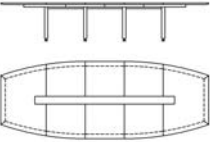
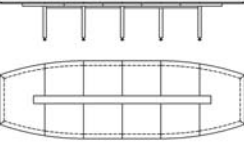
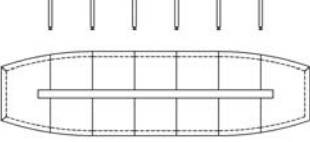
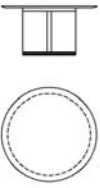
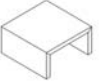
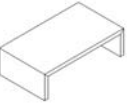
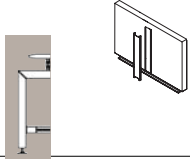

ARTICOLO ITEM ARTICLE	CODICE E DESCRIZIONE CODE AND DESCRIPTION CODES ET DESCRIPTIONS	DIMENSIONI DIMENSIONS DIMENSIONS	
	RTC250 Tavolo da consiglio Boardroom table Table de réunion	cm 250x143xh73	TAVOLI DA CONSIGLIO I prestigiosi tavoli contribuiscono, grazie alle ampie possibilità della gamma, a configurare ambienti comuni di diverse funzioni: dalla riunione di lavoro più o meno formale ai momenti solenni e istituzionali della vita aziendale.
	RTC325 Tavolo da consiglio Boardroom table Table de réunion	cm 325x150xh73	BOARDROOM TABLES These prestigious boardroom tables come in a wide range of designs allowing the use of a single environment for different functions, from the formal or informal company meeting to the most significant institutional moments of company life.
	RTC400 Tavolo da consiglio Boardroom table Table de réunion	cm 400x150xh73	TABLES DE REUNION Les prestigieuses tables contribuent, grâce aux nombreuses possibilités qu'offre la gamme, à configurer des milieux communs capables de différentes fonctions: de la réunion de travail plus ou moins formelle aux moments solennels et institutionnels de la vie de l'entreprise.
	RTC475 Tavolo da consiglio Boardroom table Table de réunion	cm 475x150xh73	
	RTC550 Tavolo da consiglio Boardroom table Table de réunion	cm 550x150xh73	
	RTC0140 Tavolo da consiglio basso Low boardroom table Table de réunion bas	Ø140xh73	
	TB60 TB80 Tavolo basso Low table Table bas	cm 60x60xh40 cm 80x80xh40	
	TB140 Tavolo basso Low table Table bas	cm 140x80xh40	
	REL Elettrificazione tavoli conferenza Conference tables wire management Passage cables pour tables de réunion		



I colori, le tonalità e le finiture dei prodotti contenuti in questo catalogo, possono presentare variazioni all'originale a causa dei limiti grafici e di stampa. La Ora si riserva di apportare modifiche tecniche, dimensionali e funzionali ove ritenesse necessario, al fine di migliorare i propri prodotti.

Les couleurs, les tonalités et les finitions représentées dans ce catalogue, peuvent présenter des variations par rapport à l'original à cause des limites graphiques et de presse. Ora se réserve d'apporter des modifications techniques, dimensionnelles et fonctionnelles au cas où elle le considère nécessaire afin d'améliorer ses produits.

Colours, shades and finishing of all products represented in this catalogue can present variations compared to the original ones due to graphic and press limits. Ora reserves to introduce technical, dimensional and functional changes where deemed necessary in order to improve its own products.



